

**WHO**

**SYSCOM:** NAVSEA

**Sponsoring Program:** PMS 404, Undersea Weapons Programs Office

**Transition Target:** MK39 Expendable Mobile Anti-Submarine Warfare (ASW) Training Target (EMATT)

**TPOC:** (401) 832-3730

**Other Transition Opportunities:** Adjacent markets include mobile countermeasures (PMS 415/NUWC Code 15), small deep diving UUVs for subsea seabed warfare (ONR Code 32 FSUSW INP), submarine launched decoys (PMS 404), and UUV undersea mobile communication nodes (PMS 485/PMW 770). Current commercial applications in oceanography profiling, water sampling, and other underwater data collection can benefit from this high-efficiency motor technology. High-Efficiency, light-weight, compact and affordable electric motor for the MK39 EMATT incorporates contra-rotating dual motors.

**Notes:** This compact, efficient, light-weight and affordable electric motor for the MK39 EMATT incorporates contra-rotating dual motors. It delivers 95% efficiency and over 1.15 Nm torque at 4050 rpm, offering significant advantages for high sprint speed run profile options.

1. 95% efficient motor design – the motor is optimized using software combining artificial intelligence (AI), genetic algorithms, and finite element analysis (FEA) to find designs along the Pareto frontier. The motor also features novel stator teeth with proprietary material combinations and processes to minimize stator core losses.
2. Contra-rotating electric motor streamlines EMATT propulsion integration and reduces cost: Inherent roll control eliminates the need for complex pre- or post-swirl stators, independent torque-balance actuators, or static fin deflection, thereby increasing control authority and reducing drag.
3. The design offers high low-speed torque with direct-drive and specialized controllers, further minimizing torque ripple and back-EMF harmonics resulting in overall lower radiated noise.

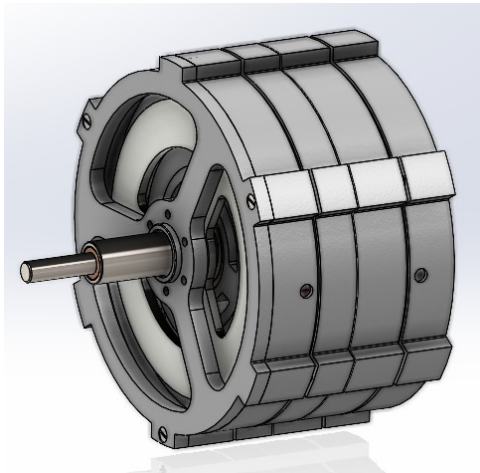

High-Efficiency, light-weight, compact and affordable electric motor for the MK39 EMATT incorporating contra-rotating dual motors

**WHAT**

**Operational Need and Improvement:** Modernize, innovate, and enhance the efficiency of the MK39 Expendable Mobile Anti-Submarine Warfare (ASW) Training Target (EMATT) motor to enable short duration high speed sprints without excessive radiated noise or compromising current low speed performance.

**Specifications Required:** To meet operational needs, the motor design requires a test point efficiency of over 80% at 4050 RPM, with a minimum torque requirement of 1.15 Nm. In addition, the total weight of the motor should not exceed 2 pounds, and its length must be limited to a maximum of 2.5 inches. The production cost for the new motor should be less than \$1,250.

**Technology Developed:** Developed an innovative contra-rotating, highly efficient, affordable, light-weight and low-noise electric motor for the MK39 EMATT MOD 4 high speed variant.

**Warfighter Value:** This new motor will have a cost less than or equal to the current MK39 EMATT MOD 3 motor while providing a 10-12% increase in energy efficiency at high sprint speeds. Once matured, this technology could be scaled up to larger UUVs or be incorporated into analogous air or surface launched A-Sized form factored UUVs for delivery of kinetic effects.

**WHEN**

**Contract Number:** N00024-25-C-S008

**Ending on:** Nov 07, 2025

Milestone	Risk Level	Measure of Success	Ending TRL	Date
Simulation Performance	Medium	>90 efficiency at 4050 rpm and 1.15 Nm	3	3rd QTR FY25
Efficiency Test in Dynamometer	Medium	>90 efficiency at 4050 rpm and 1.15 Nm in dynamometer	4	1st QTR FY26
Acoustic Evaluation	Medium	TBD/Classified	4	4th QTR FY26
Extended Duration and Thermal Evaluation	Medium	TBD/Classified	5	1st QTR FY27
Integration Test	Medium	TBD/Classified	6	4th QTR FY27

**HOW**

**Projected Business Model:** The motor will be sold as a component for an UUV (Unmanned Underwater Vehicles) or as a complete propulsion system that consists of the motor, controller, shaft and propeller. The motor and propulsion system can be customized to specific UUV requirements.

**Company Objectives:** The company's objective is to mature and prove this technology, initially incorporate the motor into the Mk 39 EMATT MOD 4 high speed variant, and later offer the design as an option for future small UUV applications, including decoys or kinetic effectors.

**Potential Commercial Applications:** Micro-AUV market, where high speed and efficiency are differentiators. Current commercial applications for oceanographic profiling, water sampling, and other underwater data collection. This technology can also be utilized in aeronautical applications where efficiency and torque density are differentiators.

**Contact:** Triton Systems, [info@tritonsystems.com](mailto:info@tritonsystems.com)